

MOTOR DRIVE TERMINALS

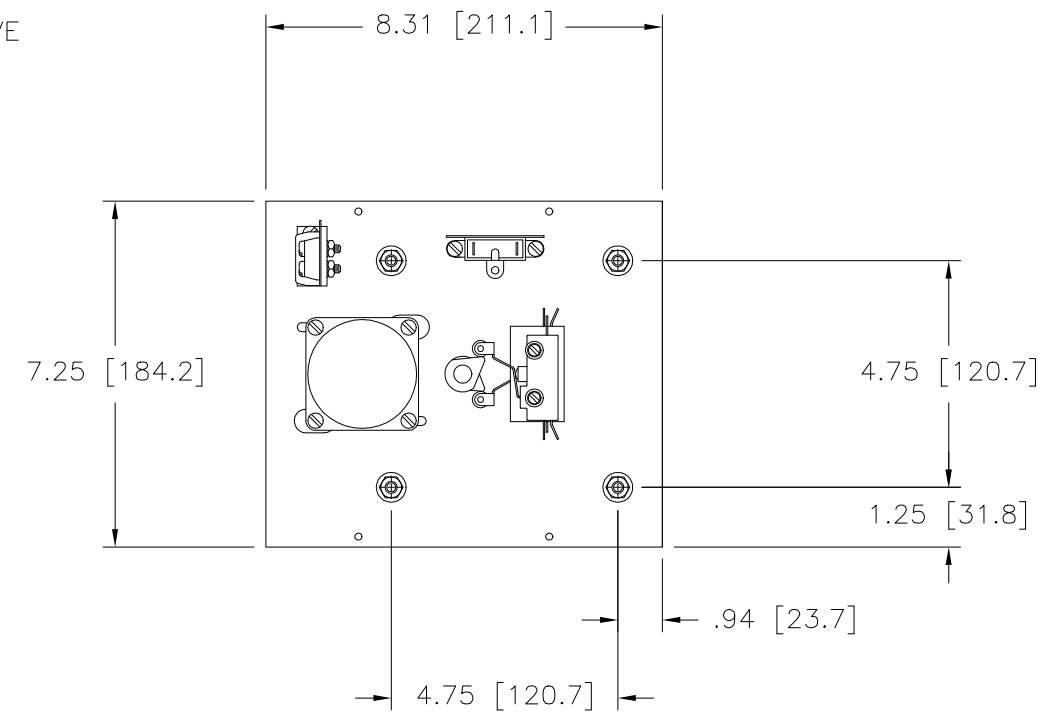

NOTES:

- JUMPER PROVIDED IN THE STANDARD COMMON POSITION AND SHOULD BE MOVED OR REMOVED AS REQUIRED.
- ++ LINE TO LINE VOLTAGE
- TT IF GANGED UNITS ARE USED IN A SYSTEM THAT ORDINARILY HAS A COMMON NEUTRAL OR GROUND BETWEEN SOURCE AND LOAD, THE NEUTRAL OR GROUND MUST BE CONNECTED TO THE COMMON TERMINALS OF THE VARIABLE TRANSFORMER ASSEMBLY. IF THE SYSTEM HAS NO NEUTRAL, THE LOAD MUST BE BALANCED OR THE TRANSFORMER WILL BE DAMAGED.
- # MAXIMUM OUTPUT CURRENT IN OUTPUT VOLTAGE RANGE FROM 0 TO 25% ABOVE LINE VOLTAGE. AT HIGHER OUTPUT VOLTAGES, THE OUTPUT CURRENT MUST BE REDUCED ACCORDING TO THE DERATING CURVE FIGURE A.
- S MAXIMUM KVA AT MAXIMUM OUTPUT VOLTAGE AND CORRESPONDING DERATED OUTPUT CURRENT. MAXIMUM KVA FOR LOWER VOLTAGES MAY BE CALCULATED FROM DERATING DERATING CURVED FIGURE A.

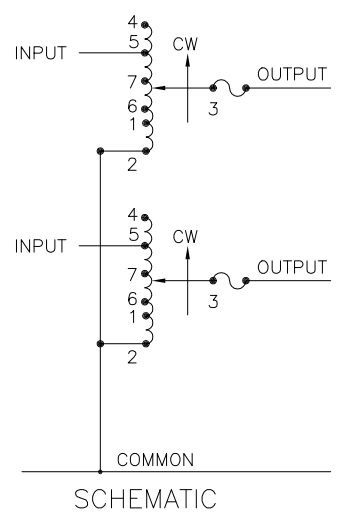

NOTE:  
 FUSE RECOMMENDED BUT NOT SUPPLIED

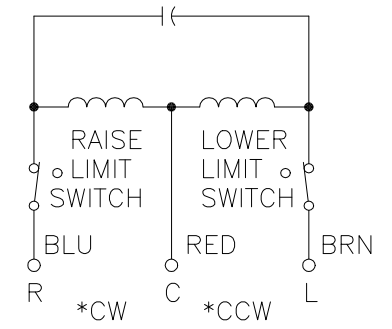

MOTOR CIRCUIT  
 120V, 50/60 HZ  
 \* ROTATION AS VIEWED FROM MOTOR END  
 MOTOR SPEED: SEE CHART

SPECIFICATIONS											
WIRING	INPUT		OUTPUT				SHAFT ROTATION TO INCREASE VOLTAGE	TERMINAL CONNECTIONS			
	VOLTS	HERTZ	VOLTS	CONSTANT CURRENT LOAD		CONSTANT IMPEDANCE LOAD		FOR INCREASING VOLTAGE AS VIEWED FROM BASE END			
				MAX. AMPS	MAX. KVA	MAX. AMPS		MAX. KVA	INPUT	JUMPER	OUTPUT
SINGLE PHASE SERIES	480	50/60	0-480	9.5	4.56	12	5.76	CW	2-2	4-4	3-3
			0-560	9.5	5.32	—	—	CCW	4-4	2-2	3-3
	240	50/60	0-560	9.5#	2.28\$	—	—	CW	1-1	4-4	3-3
			0-280	9.5	1.98\$	—	—	CCW	5-5	2-2	3-3
THREE PHASE OPEN DELTA TT	240++	50/60	0-240	9.5	3.95	12	5.0	CW	7-7	4-4	3-3
			0-280	9.5	4.61	—	—	CCW	2-4-2	4-4	3-4-3
			0-280	9.5	4.61	—	—	CW	4-2-4	2-2	3-2-3
	120++	50/60	0-280	9.5#	1.98\$	—	—	CCW	1-4-1	4-4	3-4-3
			0-280	9.5#	1.98\$	—	—	CW	5-2-5	2-2	3-2-3
			0-280	9.5#	1.98\$	—	—	CCW	7-4-7	4-4	3-4-3
0-280	9.5#	1.98\$	—	—	CCW	6-2-6	2-2	2-4-2			

SPEED (SECONDS)	MODEL NUMBER	DIM "A"
5	5M1520-2	16.36 [415.5]
15	15M1520-2	16.36 [415.5]
30	30M1520-2	16.75 [425.4]
60	60M1520-2	16.75 [425.4]

UNLESS OTHERWISE SPECIFIED, TOLERANCE IS ± DECIMALS HOLES ANGLES DRAFT  
 .XX .0005 ±.06 .002 1° 1-1/2°  
 .XXX .005

MATERIAL: ALL DIMENSIONS APPLY AFTER PLATING

UNITS IN [mm]

TITLE: SPEC. CONTROL DRAWING  
 MOTORIZED VARIABLE XFMR.  
 5, 15, 30, & 60M1520-2

DRAWN BY: TIM RAU DATE: 1/22/02 FIRST USED ON: DO NOT SCALE DWG.  
 CHECKER: DATE: WEIGHT APPROX. 52.5 LBS. CAGE CODE 83008  
 ENGINEER: DATE: SCALE .5=1 SHEET 1 OF 1

STACO ENERGY PRODUCTS CO.  
 A Components Corporation of America Company  
 302 Gaudin Boulevard Dayton, Ohio 45403 USA

DWG. NO. 031-4034