

DATE	DESCRIPTION	REV.
10.08.13	CHANGE AS PER ECN 13-091	A
3.30.17	CHANGE AS PER ECN 17-028	B

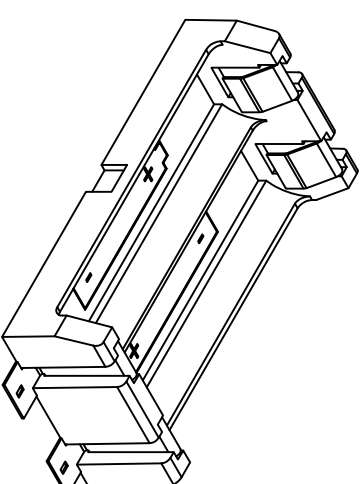
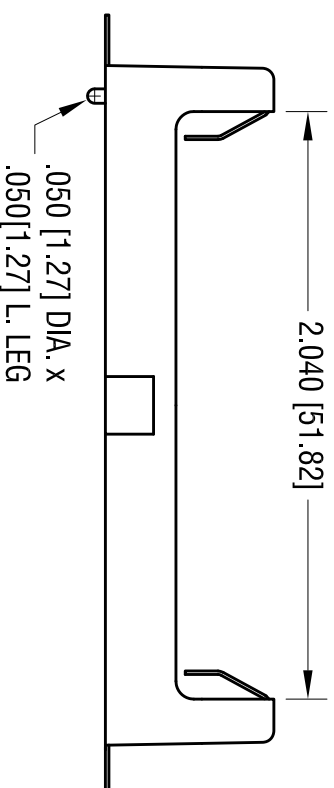
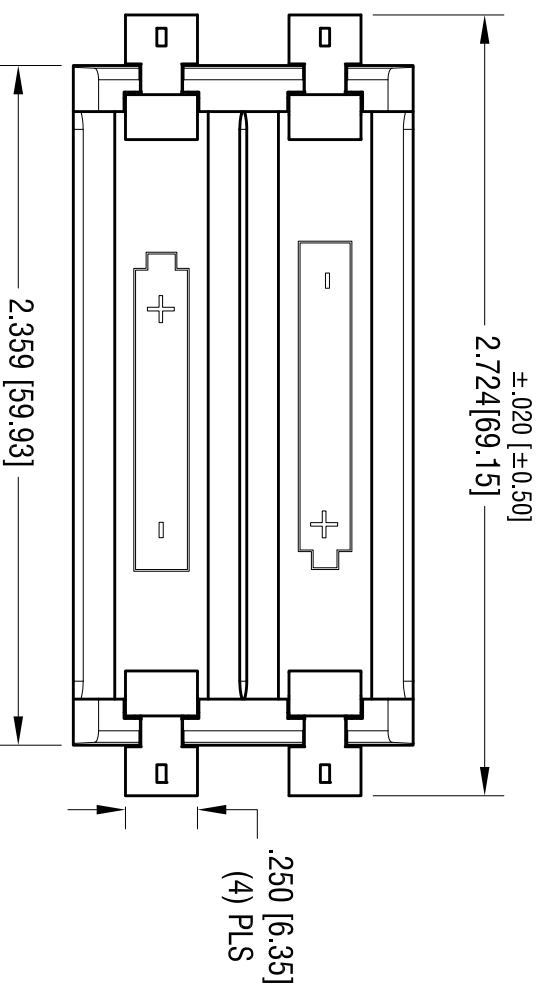
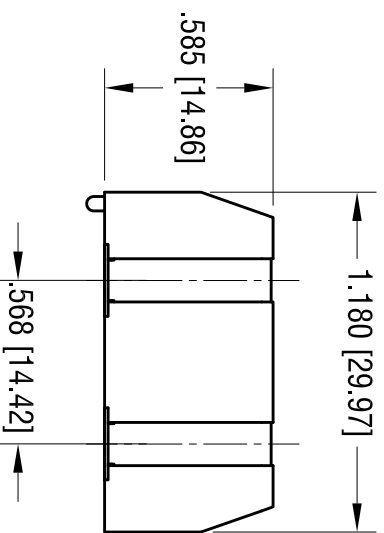
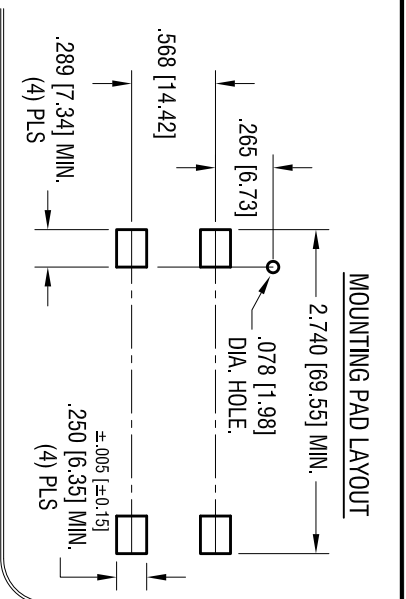

- NOTE:
1. BASE:  
MATEL: HEAT RESISTANCE NYLON  
(UL 94V-0)
  2. CONTACT:  
MATEL: .012 [0.30] THK STAINLESS STEEL  
FINISH: GOLD FLASH, OVER NICKEL PLATE.

**KEYSTONE ELECTRONICS CORP.**

www.keystone.com • ASTORIA, N.Y. 11105-2017 • Tel (718) 956-8900

PART NAME

SM BATTERY HOLDER, (2) AA

MATERIAL

AS NOTED

FINISH

AS NOTED

TOLERANCES INCH [MM]  
DECIMAL ± .010 [± 0.25]  
ANGULAR ± 1°

CODE C

DRN BY NT  
App'D LN  
DWG NO.

DATE 5.18.10  
SCALE 1.5X  
1012

THIS DOCUMENT IS THE PROPERTY OF  
KEYSTONE ELECTRONICS CORP. AND  
SHALL NOT BE REPRODUCED, DISTRIBUTED  
OR USED AS A BASIS FOR MANUFACTURE  
WITHOUT PRIOR WRITTEN PERMISSION  
FROM KEYSTONE ELECTRONICS CORP.