

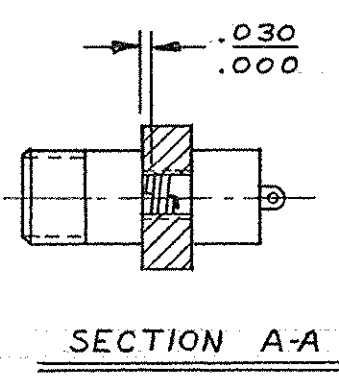

© COPYRIGHT 19 BY AMP INCORPORATED, HARRISBURG, PA. ALL INTERNATIONAL RIGHTS RESERVED. AMP INCORPORATED PRODUCTS COVERED BY U. S. AND FOREIGN PATENTS AND/OR PATENTS PENDING.

REVISIONS						
P	F	ZONE	LTR	DESCRIPTION	DATE	APPROVED
	✓		E	REDRAWN & UP-DATED ECN 8375 P.G.R.	8-29-78	m.g.
	✓		F	REV PER ECN S-3960	4-15-87	RB
			G	REV PER OH14-0192-05	1-06	PY

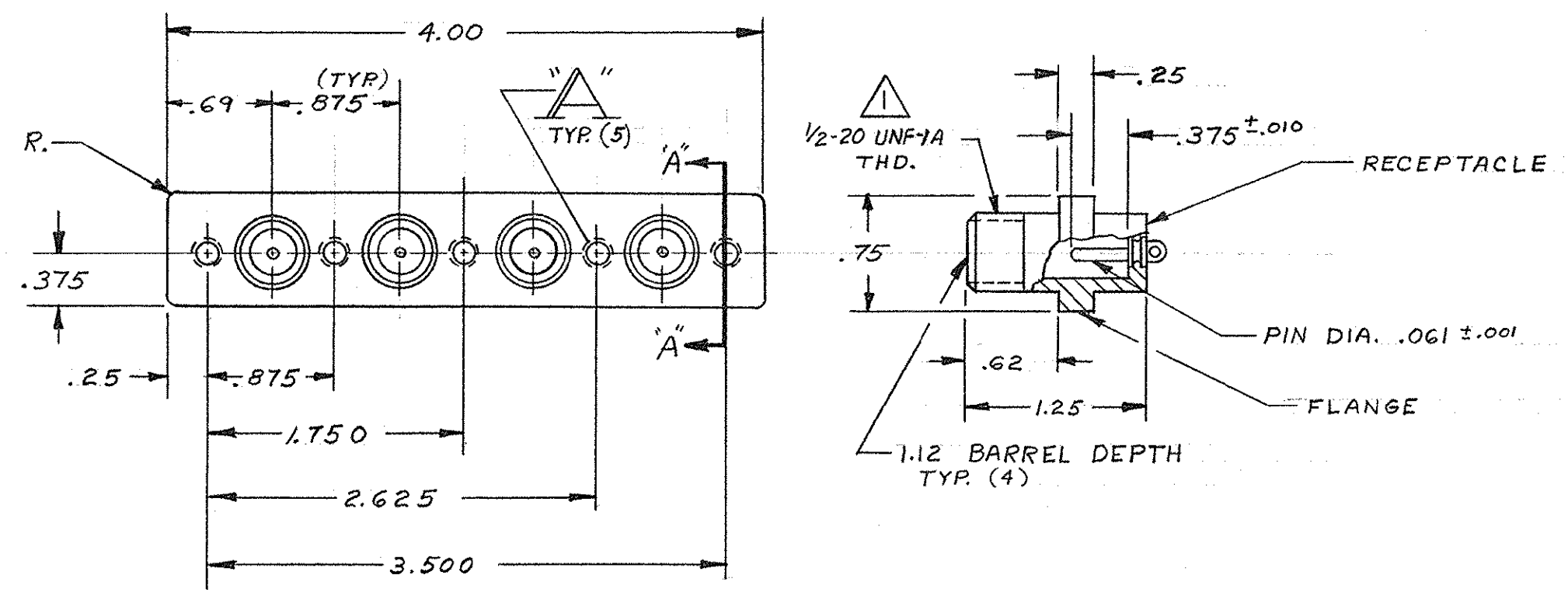

⚠ PER FEDERAL STANDARD H-28 3 WIRE METHOD. DIMENSION OVER WIRES TO BE: .497-.510.

#4-40 NON-LOCKING INSERT	AS SHOWN WITH TIN PLATED PIN	5-861485-1
*4-40 NON-LOCKING INSERT	AS SHOWN WITH GOLD PLATED PIN	861485-6
*4-40 NON-LOCKING INSERT	AS SHOWN WITH TIN-LEAD PLATED PIN	861485-5
.128 DIA. HOLE	AS SHOWN WITH GOLD PLATED PIN	861485-4
.128 DIA. HOLE	AS SHOWN WITH TIN-LEAD PLATED PIN	861485-3
*4-40 LOCKING INSERT	AS SHOWN WITH GOLD PLATED PIN	861485-2
*4-40 LOCKING INSERT	AS SHOWN WITH TIN-LEAD PLATED PIN	861485-1
A	DESCRIPTION	PART NO

UNLESS OTHERWISE SPECIFIED DIMENSIONS ARE IN INCHES. TOLERANCES: .00 ±.03 .000 ±.015 ANGLES ±				CONTRACT NO		 AMP INCORPORATED Elizabethtown, Pa.	
MATERIAL MOLDED GLASS EPOXY				DR D. MEYER 5/9/73			
FINISH BLACK				CHK		SIZE C	
NEXT ASSY				APPD M. GARDNER 5/10/73		CODE IDENT NO 00779	
FINAL ASSY				DSGN APPD		DRAWING NO 861485	
NEXT ASSY				OTHER APPD		SCALE	
USED ON				QTY REQD		SHEET 10/1	
APPLICATION							